



## Dehumidifier – User’s Guide

Model: IDM50-SE22 - 50 Pints

IDM50-SE26-P - 50 Pints

### IMPORTANT NOTE:



Before using your air conditioner, please read this manual carefully and keep it for future reference.

v.1.0



# CONTENTS

Safety precautions ..... 01

## **Get to know your product**

Get to know your product ..... 04

Get to know your features ..... 07

## **Dump the collected water**

Dump the collected water ..... 10

Care and Maintenance ..... 15

Troubleshooting ..... 16

# Safety Precautions

**Must read the warning message.**

Read Safety Precautions Before Operation and Installation To prevent death or injury to the user or other people and property damage, the following instructions must be followed. Incorrect operation due to ignoring of instructions may cause death, harm or damage.

## Explanation of Symbols



### **Warning**

The signal word indicates a hazard with a medium level of risk which, if not avoided, may result in death or serious injury.



### **Caution**

The signal word indicates a hazard with a low degree of risk which, if not avoided, may result in minor or moderate injury.



### **Never do this**

This signal indicates the prompt operation is prohibited., if not avoided, may result in Product damaged or injury.



### **Always do this**

This signal means that the operation can be performed.

## WARNING

- Do not exceed the rating of the power outlet or connection device.
- Do not operate or stop the unit by switching on or off the power.
- Do not damage or use an unspecified power cord.
- Do not modify power cord length or share the outlet with other appliances.
- Do not insert or pull out plug with wet hands.
- Do not install the appliance in a location that may be exposed to combustible gas.
- Do not place the unit near a heat source.
- Disconnect the power if strange sounds, smell, or smoke comes from it.
- You should never try to take apart or repair the unit by yourself.
- Before cleaning, turn off the power and unplug the unit.
- Do not use the machine near flammable gas or combustibles, such as gasoline, benzene, thinner, etc.
- Do not drink or use the water drained from the unit.
- Do not take the water bucket out during operation.
- Do not use the unit in small spaces.
- Do not put in places where water may splash onto the unit.
- Place the unit on a level, sturdy section of the floor.
- Do not cover the intake or exhaust openings with cloths or towels.
- Care should be taken when using the unit in a room with the following persons: infants, children, elderly people, and people not sensitive to humidity.
- Do not use in areas where chemicals are handled.
- Never insert your finger or other foreign objects into grills or openings. Take special care to warn children of these dangers.
- Do not place heavy object on the power cord and take care so that the cord is not compressed.
- Do not climb up on or sit on the unit.
- Always insert the filters securely. Clean filter once every two weeks.
- If water enters the unit, turn the unit off and disconnect the power, contact a qualified service technician.
- Do not place flower vases or other water container on top of the unit.
- Do not use extension cords.

## CAUTION

- This appliance is not intended for use by persons (including children) with reduced physical, sensory or mental capabilities or lack of experience and knowledge, unless they have been given supervision or instruction concerning use of the appliance by a person responsible for their safety. Children should be supervised to ensure that they do not play with the appliance.
- If the supply cord is damaged, it must be replaced by the manufacturer, its service agent or similarly qualified persons in order to avoid a hazard.
- Prior to cleaning or other maintenance, the appliance must be disconnected from the supply mains.
- Do not install the appliance in a location that may be exposed to combustible gas. If combustible gas accumulates around the unit, it may cause fire.
- If the appliance is knocked over during use, turn off the unit and unplug it from the main power supply immediately. Visually inspect the unit to ensure there is no damage. If you suspect the unit has been damaged, contact a technician or customer service for assistance.

## CAUTION

- In a thunderstorm, the power must be cut off to avoid damage to the machine due to lightning.
- Do not run cord under carpeting. Do not cover cord with throw rugs, runners, or similar coverings. Do not route cord under furniture or appliances. Arrange cord away from traffic area and where it will not be tripped over.
- Do not operate unit with a damaged cord or plug. Discard unit or return to an authorized service facility for examination and/or repair.
- To reduce the risk of fire or electric shock, do not use this fan with any solid-state speed control device.
- The appliance shall be installed in accordance with national wiring regulations.
- Contact the authorised service technician for repair or maintenance of this unit.
- Turn off the product when not in use.
- The manufactures nameplate is located on the rear panel of the unit and contains electrical and other technical data s pecific to this unit.
- Be sure the unit is properly grounded. To minimize shock and fire hazards, proper grounding is important. The power cord is equipped with a three-prong grounding plug for protection against shock hazards.
- Your unit must be used in a properly grounded wall receptacle. If the wall receptacle you intend to use is not adequately grounded or protected by a time delay fuse or circuit breaker(please refer to the nameplate for the electrical data), have a qualified electrician install the proper receptacle.
- Do not operate your air conditioner in a wet room such as a bathroom or laundry room.
- The unit s circuit board(PCB) is designed with a fuse to provide overcurrent protection.specifications of the fuse are printed on the circuit board, such as:T 3.15A/250V (or 350V), etc.

## Electronic Work



### WARNING:

BEFORE PERFORMING ANY ELECTRICAL OR WIRING WORK, TURN OFF THE MAIN POWER TO THE SYSTEM.

### Electronic Type

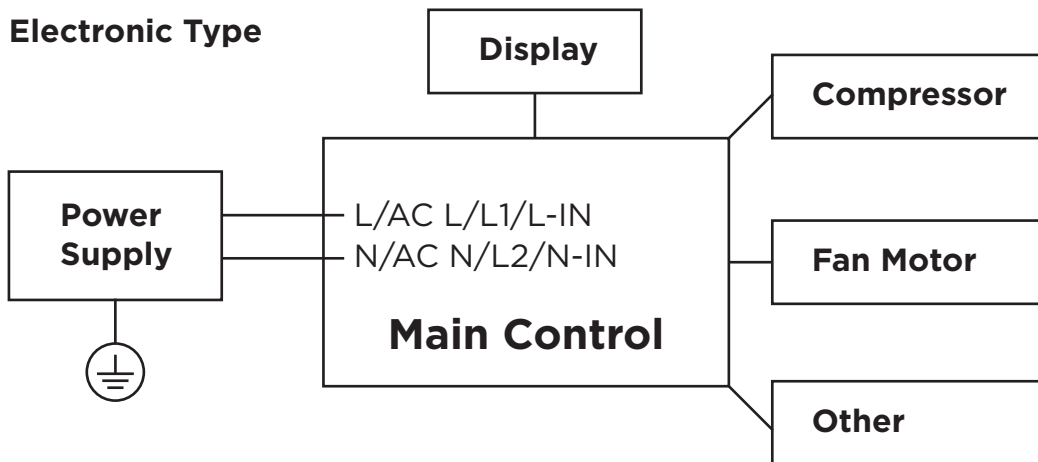

**NOTE:** Please strictly follow the wiring label attached to the machine for all wiring connections. The wiring diagram may vary for different unit. Please refer to the wiring diagram on the machine you have purchased. The above wiring diagram is a simplified version for preliminary illustration purposes only.

# Get to know your product

Name of each component of the product

## Identification of parts

### NOTE

All the illustrations in the manual are for explanation purpose only. Your machine may be slightly different. The actual shape shall prevail. The unit can be controlled by the unit control panel alone or with the remote controller. This manual does not include Remote Controller Operations, see the <<Remote Controller Instruction>> packed with the unit for details.

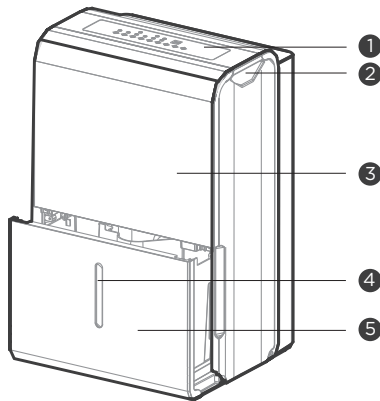

Type A

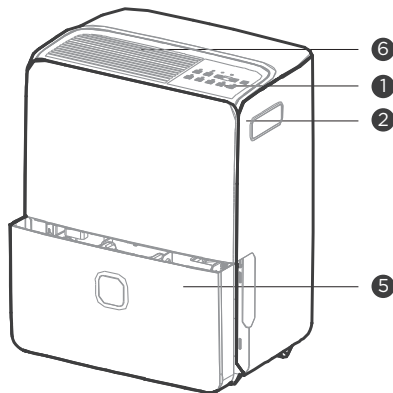

Type B

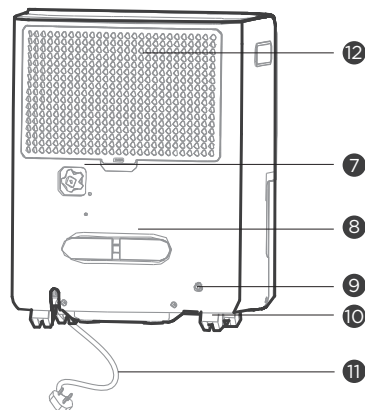
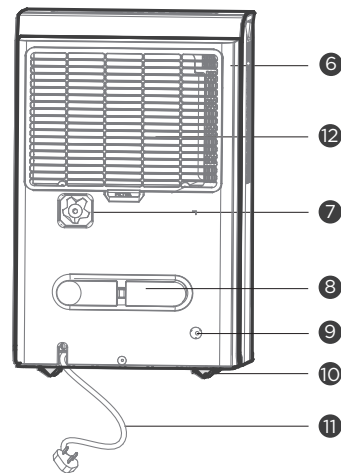

- ① Control panel
- ② Handle(both sides)
- ③ Panel
- ④ Water level window
- ⑤ Water bucket
- ⑥ Air outlet grille
- ⑦ Continuous drain hose outlet
- ⑧ Power cord buckle(placed in the water bucket,used only when storing the unit)
- ⑨ Pump drain hose outlet  
(For models with pump draining feature)
- ⑩ Caster
- ⑪ Power cord and plug
- ⑫ Air filter

# Positioning the unit

## Safe distance requirements

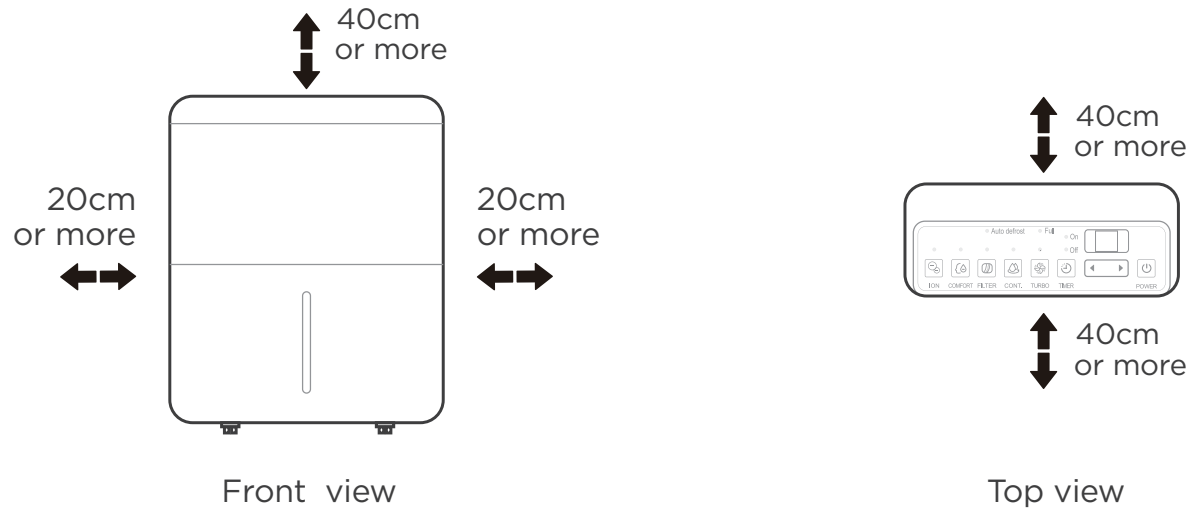

Casters(At four points on the bottom of unit)

- Casters can move freely.
- Do not force casters to move over carpet, nor move the unit with water in the bucket. (The unit may tip over and spill water.)

A dehumidifier operating in a basement will have little or no effect in drying an adjacent enclosed storage area, such as a closet, unless there is adequate circulation of air in and out of the area.

Do not use outdoors.

- This dehumidifier is intended for indoor residential applications only.
- This dehumidifier should not be used for commercial or industrial applications.

Place the dehumidifier on a smooth, level floor strong enough to support the unit with a full bucket of water.

- Allow at least 20cm of air space on all sides of the unit for good air circulation (at least 40cm of air space on air outlet).

- Place the unit in an area where the temperature will not fall below 5° C(41° F). The coils can become covered with frost at temperatures below 5° C(41° F), which may reduce performance.
- Place the unit away from the clothes dryer, heater or radiator.
- Use the unit to prevent moisture damage anywhere books or valuables are stored.
- Use the dehumidifier in a basement to help prevent moisture damage.
- The dehumidifier must be operated in an enclosed area to be most effective.
- Close all doors, windows and other outside openings to the room.

# When using your product

## Preparations for product use.

- When first using the dehumidifier, operate the unit continuously 24 hours. Make sure the plastic cover on the continuous drain hose outlet is installed properly so there are no leaks.
- This unit is designed to operate with a working environment between 5°C/41°F and 32°C/90°F, and between 30%(RH) and 80%(RH).
- If the unit has been switched off and needs to be switched on again quickly, allow approximately three minutes for the correct operation to resume.
- Do not connect the dehumidifier to a multiple socket outlet, which is also being used for other electrical appliances.
- Select a suitable location, making sure you have easy access to an electrical outlet.
- Plug the unit into an electrical socket-outlet with earth connection.
- Make sure the Water bucket is correctly fitted otherwise the unit will not operate properly.

### NOTE

When the water in the bucket reaches to a certain level, please be careful to move the machine to avoid it falling down.

## Accessories and power cord buckle installation

### Accessories

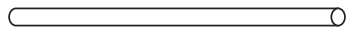

pump drain hose\*1 pc  
(For the unit with pump feature)

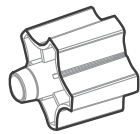

female threaded end\*1 pc  
(on some models)

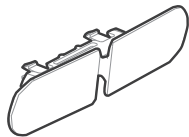

power cord bucket(1 pc)

### installation of the power cord bucket

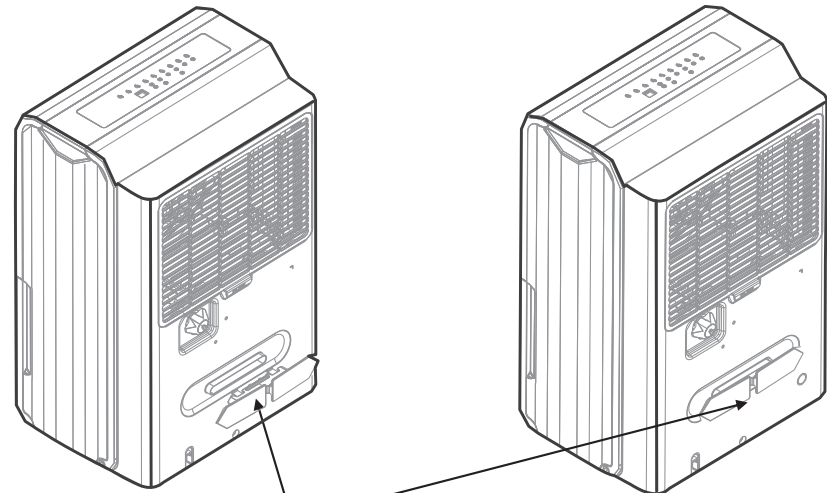

Insert the power cord buckle into the unit.

# Get to know your features

## Control Panel Features

### NOTE

The following control panels are for explanation purpose only. The control panel of the unit you purchased may be slightly different according to the models. Your machine may not contain some indicators or buttons. The actual shape shall prevail.

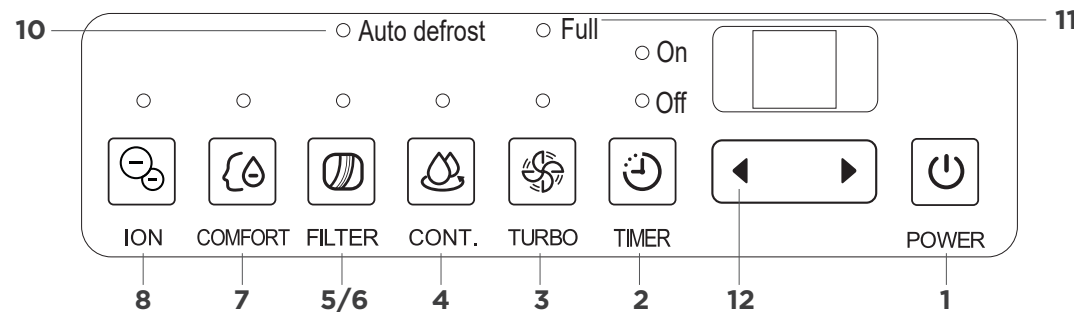

### 1.POWER button

Press to turn the dehumidifier on and off.

### 2.Timer button

Press to initiate the Auto start and Auto stop feature, in conjunction with the ◀ and ▶ (or < and > ) buttons.

### 3.TURBO Pad

Control the fan speed. Press to select either High or Normal fan speed. Set the fan control to High for maximum moisture removal. When the humidity has been reduced and quiet operation is preferred, set the fan control to Normal.

### 4.CONTINUE button

Press to activate the continuous dehumidifying operation.

### 5.FILTER button

The check filter feature is a reminder to clean the Air Filter for more efficient operation. The Filter light (Clean filter light) will illuminate after 250 hours of operation. To reset after cleaning the filter, press the Filter button and the light will go off.

### 6.WIRELESS button

Press the filter button for 3 seconds when the unit is on or off to initiate the Wireless connection mode. The LED DISPLAY shows 'AP' to indicate you can set Wireless connection and the compressor is forced off. If connection (router) is successful within 8 minutes, the unit will exit Wireless connection mode automatically and the Wireless indicator illuminates and the compressor reverts previous state. If connection is failure within 8 minutes, the unit exits the Wireless connection mode automatically.

### 7.COMFORT button

Press to activate the comfort dehumidifying operation.

**Note:** On this operation, the unit can not be set humidity level. For some models, under comfort dehumidifying operation, press Up/Down button will cancel this feature.

### 8.ION button

Press to activate the ionizer. Anions are automatically generated by ionization. The anions deactivate the airborne chemical vapors and dust particles. Press it again to stop the function.

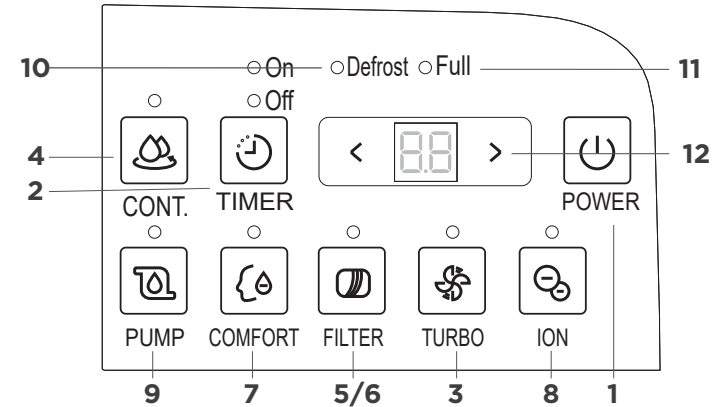
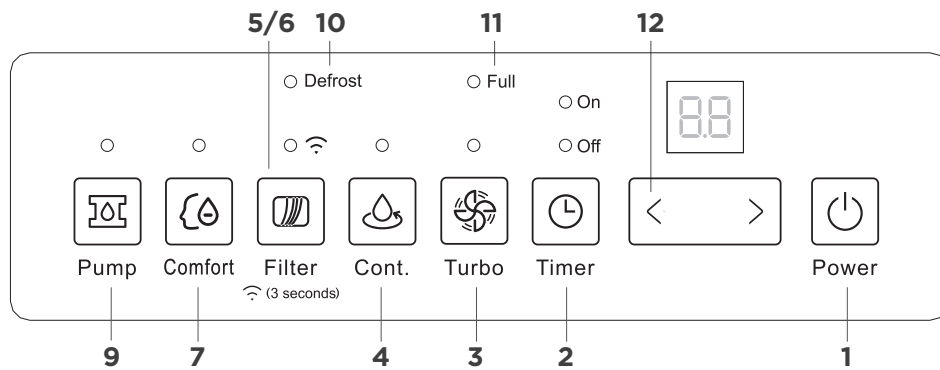

### 9.PUMP button

Press to activate the pump operation.

**NOTE:** Make sure the pump drain hose is installed into the unit and the continuous drain hose is removed from the unit before the pump operation is activated. When the bucket is full, the pump starts to work. Refer to the next pages for removing the collected water. Do not use this operation when the outdoor temperature is equal to or less than 0° C (32° F).

### 10.Auto Defrost

When frost builds up on the evaporator coils, the compressor will cycle off and the fan will continue to run until the frost disappears.

### 11.Bucket Full Light

Glows when the bucket is ready to be emptied.

### 12.UP/DOWN buttons

- Humidity Set Control buttons

The humidity level can be set within a range of 35% RH (Relative Humidity) to 85% RH (Relative Humidity) in 5% increments. For drier air, press the ◀ (or <) button and set to a lower percent value (%). For damper air, press the ▶ (or >) button and set a higher percent value (%).

- TIMER Set Control buttons

Use the Up/Down buttons to set the Auto start and Auto stop time from 0.0 to 24.

### DRYER button

Press to activate the dryer operation. Press it again to stop the function.

### Display

Shows the set % humidity level from 35% to 85% or auto start/stop time (0-24) while setting, then shows the actual (±5% accuracy) room % humidity level in a range of 30% RH (Relative Humidity) to 90% RH (Relative Humidity).

#### Error Codes and Protection Code:

AS-Humidity sensor error--Unplug the unit and plug it back in. If error repeats, call for service.

ES-Tube Temperature sensor of the evaporator error-- Unplug the unit and plug it back in. If error repeats, call for service.

P2-Bucket is full or bucket is not in right position-- Empty the bucket and replace it in the right position. (only available for the unit with no pump feature.)

P2-Bucket is full -- Empty the bucket.

(only available for the unit with pump feature.)

Eb-Bucket is removed or not in right position-- Replace the bucket in the right position. (only available for the unit with pump feature.)

**Note:** When one of the above malfunctions occurs, turn off the unit, and check for any obstructions. Restart the unit, if the malfunction is still present, turn off the unit and unplug the power cord. Contact the manufacturer or its service agents or a similar qualified person for service.

## Auto Shut Off

The dehumidifier shuts off when the bucket is full, or when the bucket is removed or not replaced in the proper position. For some models, the fan motor will continue to run for 30 seconds.

Wait 3 minutes before resuming operation. After the unit has stopped, it cannot be restarted in the first 3 minutes. This is to protect the unit. Operation will automatically start after 3 minutes.

## Check filter feature

The system starts to count the time once the fan motor operates. The check filter feature can be only activated when the accumulated operation time achieves 250 hours or more. The Reset light (Clean filter indicator light) flashes at one time per second, after finishing clean the air filter, press the Filter button and the Reset light (Clean filter indicator light) goes off.

## Auto-Restart

If the unit breaks off unexpectedly due to the power cut, it will restart with the previous function setting automatically when the power resumes.

## Setting the Timer

- When the unit is on, first press the Timer button, the Timer Off indicator light illuminates. It indicates the Auto Stop program is initiated. Press it again the Timer On indicator light illuminates. It indicates the Auto Start is initiated.
- When the unit is off, first press the Timer button, the Timer On indicator light illuminates. It indicates the Auto Start program is initiated. Press it again the
- Timer Off indicator light illuminates. It indicates the Auto Stop is initiated.
- Press or hold the UP or DOWN button to change the Auto time by 0.5 hour increments, up to 10 hours, then at 1 hour increments up to 24 hours.
- The control will count down the time remaining until start.
- The selected time will register in 5 seconds and the system will automatically revert back to display the previous humidity setting.
- When the Auto Start & Auto Stop times are set, within the same program sequence, Timer On Off indicator lights illuminate identifying both On and Off times are now programmed.
- Turning the unit On or Off at any time or adjusting the timer setting to 0.0 will cancel the Auto Start/Stop function. When LED display window displays the code of P2, the Auto Start/Stop function will also be cancelled.

# Dump the collected water

When your product has been  
in use for a while.

There are three ways to remove collected water.

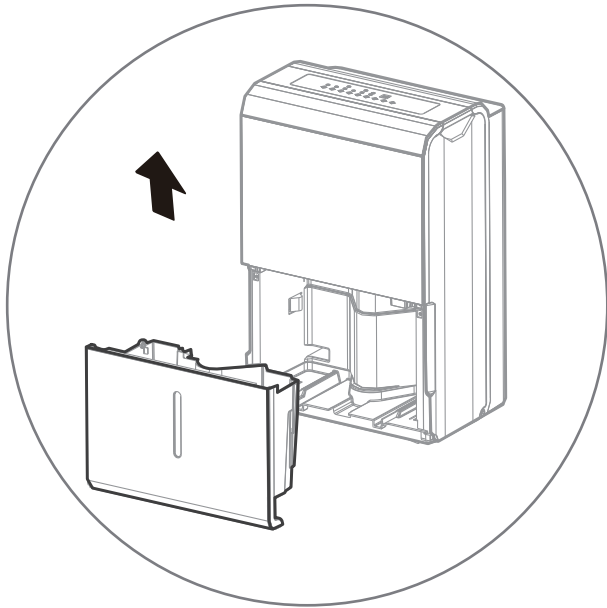

**Type 1:**

**Bucket drainage**

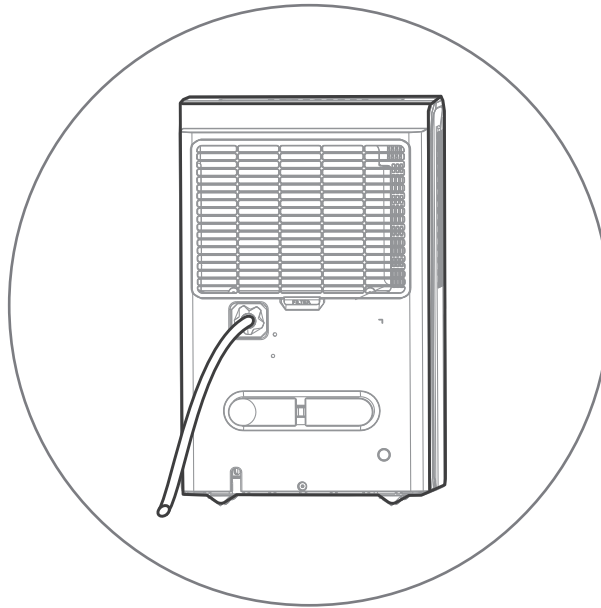

**Type 2:**

**water hose drainage  
(continuous)**

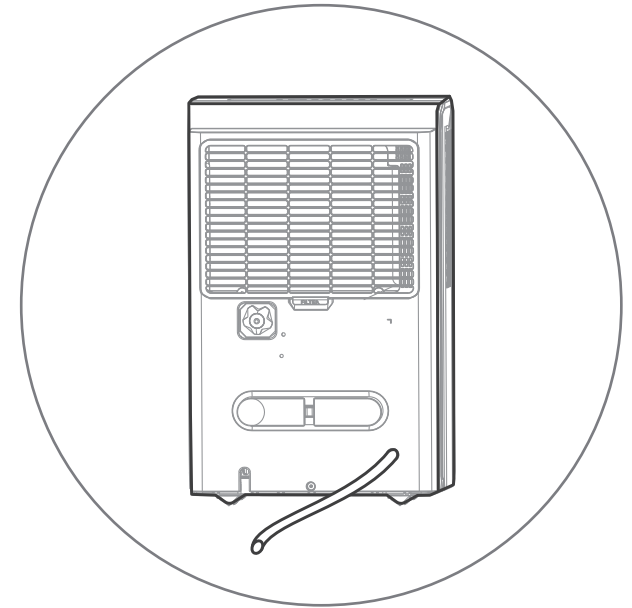

**Type 3:**

**Pump drainage  
(Pump model only)**

# Bucket drainage

Type 1

- When the unit is off, if the bucket is full, the Full indicator light will light.
- When the unit is on, if the bucket is full, the compressor and the fan turn off, and the Full indicator light will light, the digital display shows P2.
- Slowly pull out the bucket. Grip the left and right handles securely, and carefully pull out straight so water does not spill. Do not put the bucket on the floor because the bottom of the bucket is uneven. Otherwise the bucket will fall and cause the water to spill.
- Throw away the water and replace the bucket. The bucket must be in right place and securely seated for the dehumidifier to operate.
- The machine will re-start when the bucket is restored in its correct position.

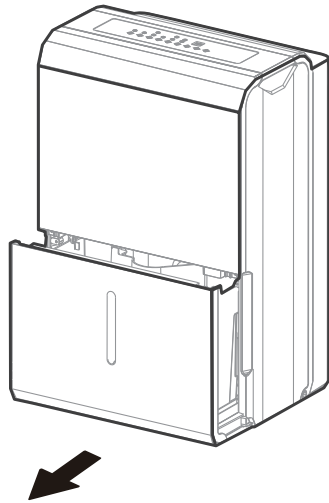

1

**Pull out the bucket a little.**

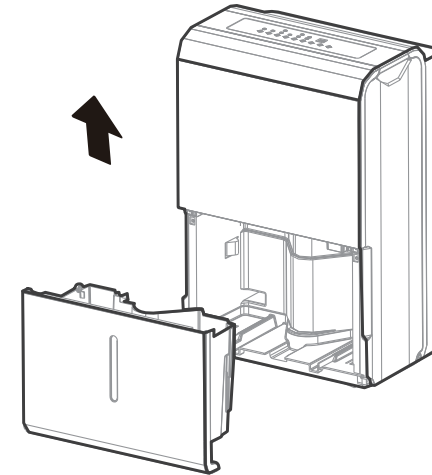

2

**Hold both sides of the bucket with even strength, and pull it out from the unit.**

3

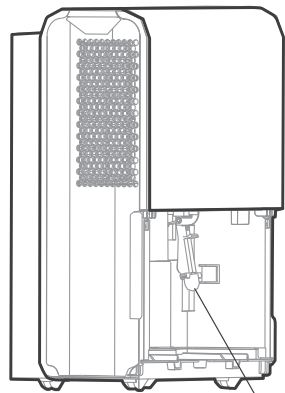

Pump the hose drops.

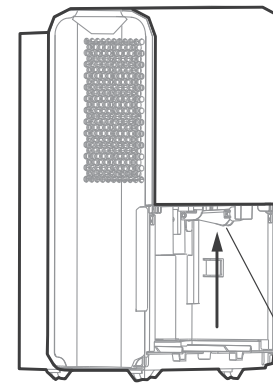

Reinstall pump hose properly

## Pour the water out.

### NOTE

- When you remove the bucket, do not touch any parts inside of the unit. Doing so may damage the product. Be sure to push the bucket gently all the way into the unit. Banging the bucket against anything or failing to push it in securely may cause the unit not to operate.
- If the pump hose drops when you remove the bucket, you must reinstall the pump hose properly to the unit before replace the bucket into the unit.
- When you remove the bucket, if there is some water in the unit you must dry it.
- When the unit is on, if the bucket is removed, the compressor and the fan turn off, then the unit will beep 8 times and the digital display shows Eb.
- When the unit is off, if the bucket is removed, the unit will beep 8 times and the digital display shows Eb.

## water hose drainage (continuous)

Type 2

- Water can be automatically emptied into a floor drain by attaching the unit with a water hose (ID  $\geq \Phi 5/16''$ , not included) with a female threaded end (ID: M=1", not included)

**Note:** On some models, the female threaded end is include.

- Remove the plastic cover from the back drain outlet of the unit and set aside, then insert the drain hose through the drain outlet of the unit and lead the drain hose to the floor drain or a suitable drainage facility.

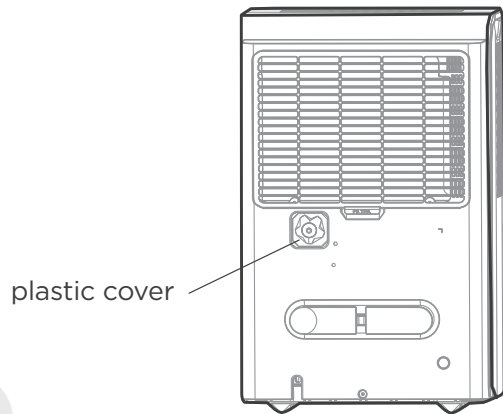

1

## Remove the plastic cover by counter-clockwise rotation.

- When you remove the plastic cover, if there is some water in the back drain outlet of the unit you must dry it. Make sure the hose is secure so there are no leaks and the end of the hose is level or down to let the water flow smoothly.
- Direct the hose toward the drain, making sure that there are no kinks that will stop the water flowing. Make sure the water hose is lower than the drain hose outlet of the unit.
- Select the desired humidity setting and fan speed on the unit for continuous draining to start.

**Note:** When the continuous draining feature is not being used, remove the drain hose from the outlet, and dry the water in the continuous drain hose outlet.

## Pump drainage (Pump model only)

Type 3

- Water can be automatically emptied into a floor drain or a suitable drainage facility by attaching the pump drain outlet with a pump drain hose ( $\Phi_{od}=1/4"$ , supplied).
- Remove the continuous drain hose from the unit and install the plastic cover to the continuous drain hose outlet of the unit by clockwise rotation.
- Resert the pump drain hose into the pump drain hose outlet for depth of 15mm at least, then lead the water hose to the floor drain or a suitable drainage facility.

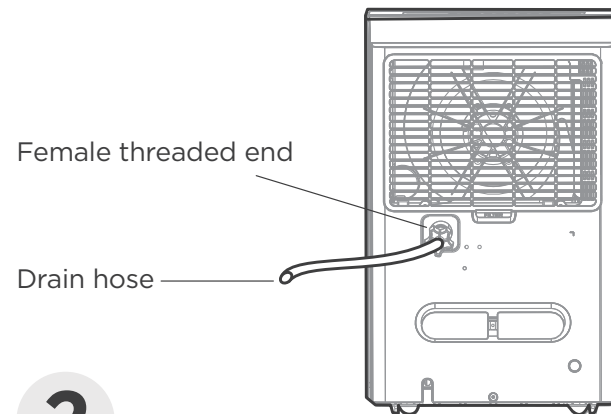

2

## Install the Female threaded end and connect the drain hose.

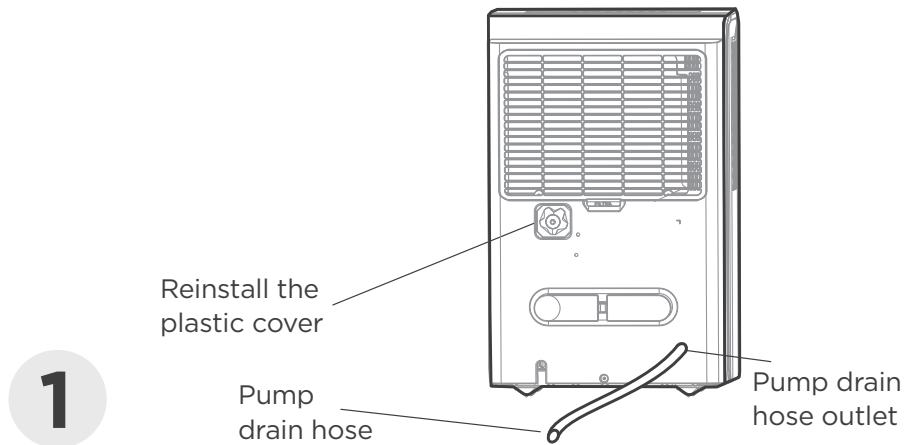

## Reinstall the plastic cover and install the pump drain hose.

- Press the pump pad of the unit to activated the pump operation. When the bucket is full the pump starts to work.

**Note:** The pump may cause big noise when it starts to work for 3-5 minutes. It is a normal phenomenon.

- Make sure the hose is secure so there are no leaks.
- Direct the hose toward the drain, making sure that there are no kinks that will stop the water flowing.
- Place the end of the hose into the drain and make sure the end of the hose is level or down to let the water flow smoothly. Do never let it up.
- select the desired humidity setting and fan speed on the unit for pump draining to start.

**Note:** The pump operation on light blinks at 1Hz when the pump is operational failure. Please turn off the unit and plug the power cord out. Check the following things: Cleaning the filter of the pump.-Remove the bucket from the unit, take down the pump and clean the filter of the pump.

- Check that the pump drain hose does not link or back.
- Empty the water of the bucket.

Reinstall the pump hose if it drops and reinstall the bucket properly. Turn on the unit. If the error repeats, call for service.

**Note:** Do not use this operation when the outdoor temperature is equal to or less than 0 °C (32°F),

otherwise water is become ice that will cause the water hose blocked up and the unit failure. Make sure to empty the bucket once a week when using the pump draining feature. When the pump draining feature is not being used, remove the pump drain hose from the outlet.

- Press the pump drain hose outlet in and take the pump drain hose out from it. Make sure do not let the water in the pump hose drip to the floor.

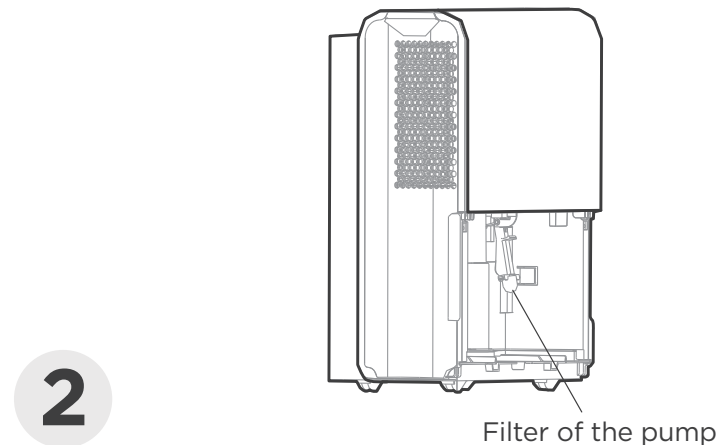

## Clean the filter pump after you have used the pump function several times.

# Care and Maintenance

How to clean & maintenance your product.

Care and cleaning of the dehumidifier Turn the dehumidifier off and remove the plug from the wall outlet before cleaning.

## Clean the Grille and Case

- Use water and a mild detergent. Do not use bleach or abrasives.
- Do not splash water directly onto the main unit. Doing so may cause an electrical shock, cause the insulation to deteriorate, or cause the unit to rust.
- The air intake and outlet grilles get soiled easily, so use a vacuum attachment or brush to clean.

## Clean the bucket

- Every few weeks, clean the bucket to prevent growth of mold, mildew and bacteria. Partially fill the bucket with clean water and add a little mild detergent. Swish it around in the bucket, empty and rinse.

**Note:** Do not use a dishwasher to clean the bucket. After clean, the bucket must be in place and securely seated for the dehumidifier to operate.

## Clean the air filter

- Remove the filter every two weeks based on normal operating conditions.
- Wash the filter with clean water then dry.
- Re-install the filter, replace Bucket.
- To remove the filter, pull filter outwards.

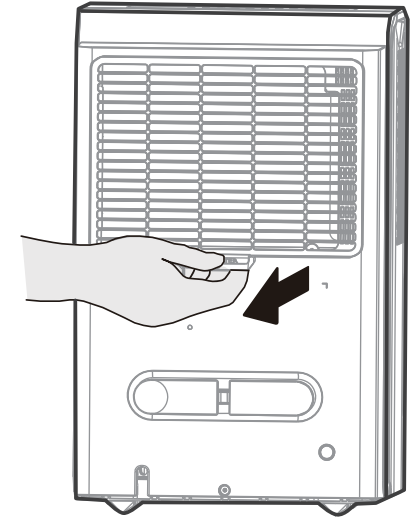

### CAUTION

DO NOT operate the dehumidifier without a filter because dirt and lint will clog it and reduce performance.

## When not using the unit for long time periods

- After turning off the unit, wait one day before emptying the bucket.
- Clean the main unit, water bucket and air filter.
- Wrap the cord with the power cord buckle.
- Cover the unit with a plastic bag.
- Store the unit upright in a dry, well-ventilated place.

# Troubleshooting

Before calling for service, review the chart below first yourself.

Problem	What to check
<b>Unit does not start</b>	<p>Make sure the dehumidifier s plug is pushed completely into the outlet.</p> <p>Check the house fuse/circuit breaker box.</p> <p>Dehumidifier has reached its preset level or bucket is full.</p> <p>Water bucket is not in the proper position.</p>
<b>Dehumidifier does not dry the air as it should</b>	<p>Did not allow enough time to remove the moisture.</p> <p>Make sure there are no curtains, blinds or furniture blocking the front or back of the dehumidifier.</p> <p>The humidity control may not be set low enough.</p> <p>Check that all doors, windows and other openings are securely closed.</p> <p>Room temperature is too low , below 5°C(41°F).</p> <p>There is a kerosene heater or something giving off water vapor in the room.</p>
<b>The unit makes a loud noise when operating</b>	<p>The air filter is clogged.</p> <p>The unit is tilted instead of upright as it should be.</p> <p>The floor surface is not level.</p>
<b>Frost appears on the coils</b>	<p>This is normal. The dehumidifier has Auto defrost feature.</p>
<b>Water on floor</b>	<p>Hose to connector or hose connection may be loose.</p> <p>Intend to use the bucket to collect water, but the back drain plug is removed.</p>
<b>ES, AS,P2,Eb appear in the display</b>	<p>These are error codes and protection codes. See the CONTROL PANEL FEATURES section.</p>
<b>The pump operation on light blinks at 1Hz</b>	<p>Clean the filter of the pump.</p> <p>Check the pump hose does not link or block.</p> <p>Empty the water of the bucket.</p>

The design and specifications are subject to change without prior notice for product improvement. Consult with the sales agency or manufacturer for details. Any updates to the manual will be uploaded to the service website, please check for the latest version.

# CUSTOMER SUPPORT

---

Before contacting customer support, please see the troubleshooting guide above.

Upon unpacking your air conditioner, please be sure to write down the model and serial number of your unit. This will be needed should your unit require servicing in the future. The number is found on a barcode on the right side of the air conditioner and on a similar barcode on the outside of the box the unit came in.

We recommend holding onto the box, but as many people do throw it away, and the air conditioner itself gets in - stalled in a window, it can be difficult to access this serial number later.

Model number: \_\_\_\_\_ (One of the numbers mentioned on the cover of this manual). Your exact number is found on your box or on the rating label sticker on the right side of the unit.

Serial number (11 digits) \_\_\_\_\_

Please keep this manual for your records!

Visit our website to contact us, find answers to Frequently Asked Questions, and for other resources which may include an updated version of this user's guide.

 [WWW.IMPECCA.COM](http://WWW.IMPECCA.COM)

If you wish to contact us by phone, please be sure to have your model number and serial number ready and call us between 9:00am and 5:00pm ET, at +1 866-954-4440.

Keep tabs on Impecca's newest innovations & enter contests via our social network feeds:

 [www.facebook.com/impecca/](http://www.facebook.com/impecca/)

 [www.instagram.com/impecca/](http://www.instagram.com/impecca/)

 @impeccausa

## ONE-YEAR LIMITED APPLIANCE WARRANTY (US)

Impecca™ warrants this product against defects in material and workmanship to the original purchaser as specified below.

**PARTS AND LABOR- if the product is determined to have a manufacturing defect, within a period of one year from the date of the original purchase, Impecca™, at its own discretion, will repair or replace the product parts at no charge to you in the U.S.A.**

To obtain warranty service by an authorized Impecca™ service center, please email us at: [service@impecca.com](mailto:service@impecca.com) to obtain a Repair and Maintenance Authorization (RMA) number and received instructions on how the repair and/or replacement procedure will take place.

**Any glass materials included with the appliance will be covered for a period of 60 days from purchase.**

Impecca™ specifically excludes from this warranty any non-electric/mechanical attachments, accessories and disposable parts including but not limited to outside case, connecting cables, batteries and AC adapters. Impecca™ reserves the right to repair or replace defective products with the same, equivalent or newer models.

We reserve the right to either repair or replace product at our discretion. Replacement may be either new or refurbished and while every endeavor will be made to ensure it is the same model, if not possible it will be equal or higher specification.

Normal "Wear and Tear" is not covered by this warranty. Further, Impecca™ hereby reserves the right to determine "Wear and Tear" on any and all products. Tampering or opening the product casing or shell will void this warranty in its entirety.

Exclusions: This warranty does not cover the following:

1. Any product that has a defaced or covered serial number.
2. Products that have been transferred to a second owner.
3. Rust on the interior or exterior of the unit.
4. Products listed as "As-Is" or "Refurbished."
5. Food loss due to any product failure.
6. Window air conditioners installed in a wall.
7. The product if used in a commercial setting.
8. Service calls that do not involve product malfunction.
9. Service calls for a product ruined by not following the provided instructions.
10. Service calls to correct improper installation.
11. Costs associated with making the product accessible for servicing (including but not limited to removal of

trim/molding/cabinetry, etc.)

12. Service calls to replace any consumables such as light bulbs, filters, etc.
13. Surcharges that may apply to service calls on weekends, nights, holidays. Damages to the finish of appliance or household furnishings due to installation of appliance.
14. Damages caused by any of the following: Acts of God; fires; misuse; accidents; incorrect power supply; service performed by unauthorized persons; use of non-genuine Impecca parts, etc.

ALL IMPLIED WARRANTIES, INCLUDING IMPLIED WARRANTIES OF MERCHANTABILITY AND FITNESS FOR A PARTICULAR PURPOSE ARE LIMITED IN DURATION TO 1 YEAR FROM THE DATE OF THE ORIGINAL RETAIL PURCHASE OF THIS PRODUCT.

THESE WARRANTIES AND REMEDIES ARE THE SOLE AND EXCLUSIVE WARRANTIES AND REMEDIES IN CONNECTION WITH THE SALE AND USE OF THE PRODUCT. NO OTHER WARRANTIES, ORAL OR WRITTEN, EXPRESSED OR IMPLIED, ARE GIVEN.

IMPECCA™ IS NOT RESPONSIBLE OR LIABLE FOR ANY DAMAGE, WHETHER SPECIAL, INCIDENTAL, CONSEQUENTIAL, DIRECT OR OTHERWISE, OR WHETHER KNOWN OR SHOULD HAVE BEEN KNOWN TO IMPECCA™, INCLUDING LOST PROFITS, GOODWILL, AND PROPERTY AND PERSONAL INJURY RESULTING FROM ANY BREACH OF WARRANTY, THE INABILITY TO USE THE PRODUCT OR UNDER ANY LEGAL THEORY IN CONTRACT OR TORT. IMPECCA LIABILITY IS LIMITED TO THE ACTUAL PURCHASE PRICE PAID TO THE RETAIL SELLER OF THE DEFECTIVE PRODUCT.

No Impecca™ dealer, agent or employee is authorized to make any modification, extension, change or amendment to this warranty without the written consent and authorization from Impecca™.

Some states do not allow the exclusion or limitation of implied warranties or liability for incidental or consequential damages, or do not allow a limitation on how long an implied warranty lasts, so the above limitations or exclusions may not apply to you. This warranty gives you specific legal rights, and you have other rights, which vary from state to state.

*Note: Our Warranty center services only to Continental U.S.A.*

## GARANTÍA LIMITADA POR UN AÑO

Impecca™ garantiza al comprador original este producto contra defectos en su material y mano de obra como se especifica a continuación.

**PARTES Y MANO DE OBRA– Si se determina que el producto tiene defectos de fabricación, dentro del periodo de un (1) año a partir de la fecha de compra original, Impecca™, a su discreción, reparará o reemplazará las partes del producto sin ningún costo para usted en los Estados Unidos.**

Para obtener el servicio de garantía de un distribuidor autorizado de Impecca™ envíenos un correo electrónico a: [service@impecca.com](mailto:service@impecca.com) para obtener un número de Autorización de Reparación y Mantenimiento (RAM) y recibir las instrucciones de cómo se llevará a cabo el procedimiento de reparación o reemplazo.

**Cualquier material de vidrio incluido en el electrodoméstico estará cubierto por un periodo de sesenta (60) días a partir de la fecha de compra.**

Impecca™ excluye de esta garantía accesorios no eléctricos o mecánicos, accesorios y partes desechables incluyendo, pero no limitado, a la carcasa, cables de conexión, baterías, adaptadores A/C. Impecca™ se reserva el derecho de reparar o reemplazar un producto defectuoso con un modelo igual, equivalente o nuevo modelo.

Nos reservamos el derecho ya sea de reparar o reemplazar el producto a nuestra discreción. El reemplazo puede ser nuevo o reacondicionado tratando de asegurar de que se trate del mismo modelo, si el mismo modelo no está disponible, se reemplazará con un modelo de especificaciones iguales o superiores.

El “desgaste” normal no está cubierto por esta ni por ninguna otra garantía. Adicionalmente, Impecca™ se reserva el derecho de determinar el “desgaste” de cualquiera o todos los productos. El violar o abrir el chasis del producto invalidará esta garantía por completo.

Excepciones: Esta garantía no cubre lo siguiente:

1. Cualquier producto que tenga un número de serie defectuoso o cubierto
2. Productos que han sido transferidos a un segundo propietario
3. Óxido en la parte interna o externa de la unidad
4. Los productos listados como “Tal cual” o “Reformados”
5. Pérdida de alimentos debido a la falla del producto
6. Aires acondicionados que han sido instalados en un muro.
7. El producto si este ha sido utilizado en una ubicación comercial
8. Llamadas de servicio que no involucren el mal funcionamiento del producto
9. Llamadas de servicio de un producto estropeado por no seguir las instrucciones proporcionadas

10. Llamadas de servicio para corregir una instalación incorrecta
11. Costos asociados por hacer el producto accesible al servicio (incluido pero no limitado a la remoción de ajustes/moldeo/gabinete, etc.)
12. Llamadas de servicio para reemplazar consumibles como bombillas, filtros, etc.
13. Recargos que pueden aplicar a llamadas de servicio los fines de semana, por las noches, o durante las festividades. Daños al acabado del electrodoméstico o muebles de la casa debido a la instalación del electrodoméstico.
14. Daños causados por cualquiera de las siguientes causas: Actos de Dios, incendios, mal uso, accidentes, suministro de energía incorrecto, servicio realizado por personal no autorizado, el uso de partes no originales Impecca.

TODAS LAS GARANTÍAS IMPLÍCITAS, INCLUYENDO LAS GARANTÍAS IMPLÍCITAS DE MERCADOTECNIA E IDONEIDAD PARA UN PROPÓSITO EN PARTICULAR ESTÁN LIMITADAS A UNA DURACIÓN DE (1) AÑO EN PARTES Y NOVENTA (90) DÍAS EN MANO DE OBRA DESDE LA FECHA ORIGINAL DE COMPRA DEL PRODUCTO.

ESTAS GARANTÍAS Y MEDIDAS SON ÚNICAS Y EXCLUSIVAS EN RELACIÓN CON LA VENTA Y USO DEL PRODUCTO. NO SE OTORGA NINGUNA OTRA GARANTÍA, ORAL O ESCRITA, EN FORMA EXPRESA O IMPLÍCITA.

IMPECCA™ NO SE HACE RESPONSABLE DE NINGÚN DAÑO, YA SEA ESPECIAL, INCIDENTAL, CONSECUENTE, DIRECTO O DE CUALQUIER OTRA NATURALEZA, YA SEA CONOCIDO O POR DAR A CONOCER A IMPECCA™, INCLUYENDO LA PÉRDIDA DE GANANCIAS, PLUSVALÍA, DAÑOS PERSONALES O EN LA PROPIEDAD RESULTANTES DE CUALQUIER INCUMPLIMIENTO DE LA GARANTÍA, LA INCAPACIDAD DE UTILIZAR EL PRODUCTO O BAJO NINGUNA TEORÍA LEGAL EN CONTRATO O AGRAVIO. LA RESPONSABILIDAD DE IMPECCA SE LIMITA AL PRECIO ACTUAL DE COMPRA PAGADO AL VENDEDOR DEL PRODUCTO DEFECTUOSO.

Ningún distribuidor, agente o empleado de Impecca™ está autorizado para hacer ninguna modificación, extensión, cambio o enmienda de esta garantía sin el consentimiento y autorización escrita de Impecca™.

Algunos estados no permiten la exclusión o limitación de garantías implícitas o la responsabilidad por daños incidentales o consecuentes, y no permiten una limitación en la duración de una garantía implícita, de modo que las anteriores limitaciones o exclusiones pueden no aplicarse a usted. Esta garantía le otorga derechos específicos, y puede usted tener otros derechos, los cuales varían de estado a estado.

*Nota: El Centro de Servicio de Garantía hace envíos solo dentro del territorio continental de E.U.*

# GARANTIE LIMITÉE D'UN AN

Impecca™ garantie auprès de l'acheteur original cet appareil contre toutes déficiences liées au matériel et à la fabrication tel que spécifié ci-dessous.

**PIÈCES ET MAIN D'ŒUVRE- S'il est déterminé que l'appareil a un problème lié à la fabrication, à l'intérieur d'une période d'un an de la date d'achat originale, Impecca™, à sa discrétion, pourra remplacer ou réparer les pièces de l'appareil sans frais pour vous aux États-Unis.**

Afin d'obtenir des services sous garantie par un fournisseur autorisé par le centre de service d'Impecca™, veuillez nous rejoindre par courriel : [service@impecca.com](mailto:service@impecca.com) afin d'obtenir un numéro d'autorisation d'entretien et réparation (Repair and Maintenance Authorization – RMA). Vous recevrez également des détails liés au processus de réparation et/ou remplacement.

**Tout matériau en verre inclus avec l'appareil est couvert par une garantie de 60 jours à compter de la date d'achat (lorsque applicable).**

Impecca™ exclus spécifiquement de cette garantie tout accessoire non électrique / mécanique, accessoires ou pièce jetable incluant, mais non limité au boîtier externe, les câbles connecteurs, les piles et les adaptateurs secteur. Impecca™ se réserve le droit de réparer ou remplacer les appareils défectueux par un modèle pareil, équivalent ou plus récent.

Nous nous réservons le droit de réparer ou de remplacer l'appareil à notre discrétion. Le remplacement pourrait être par un appareil nouveau ou remis à neuf. Bien que tous les efforts soient mis de l'avant pour assurer qu'il s'agisse du même modèle, s'il s'avère impossible, le remplacement sera de qualité similaire ou supérieure.

L'usure normale de l'appareil n'est pas couverte par cette garantie. Impecca™ se réserve le droit de déterminer le niveau d'usure sur l'ensemble de ses appareils. Ouvrir le boîtier ou modifier l'appareil annule dans son entièreté la présente garantie.

Exclusions : la garantie présente exclut les points suivants :

1. Tout appareil dont le numéro de série est effacé ou rendu illisible.
2. Tout appareil transféré à un second propriétaire.
3. La rouille formée à l'intérieur ou à l'extérieur de l'unité.
4. Les appareils marqués « Tel quel » ou « Remis à neuf ».
5. Pertes d'aliments dus à un mauvais fonctionnement de l'appareil.
6. Climatiseur à fenêtre installés au mur.
7. Si l'appareil est utilisé à des fins commerciales.
8. Appels de service qui ne sont pas en lien avec un mal fonctionnement de l'appareil.
9. Appels de service pour un appareil endommagé suite au non-respect des instructions fournies.
10. Appels de service liés à une installation défectueuse.

11. Coûts entraînés à rendre l'appareil accessible pour l'entretien (incluant, mais non limité à l'enlèvement de moulures, plinthes, armoires, etc.)
12. Appels de service pour le remplacement de pièces consommables tels que des ampoules, filtres, etc.
13. Des frais additionnels peuvent s'appliquer aux appels de service en soirée, en fin de semaine, les jours fériés. Des dommages à la finition de l'appareil ou à des ameublements suite à l'installation de l'appareil.
14. Dommages causés par : des circonstances exceptionnelles; incendie; mauvaise utilisation; accident; alimentation électrique inappropriée; entretien effectué par une personne non autorisée; utilisation de pièces non d'origine d'Impecca, etc.

TOUTE GARANTIE IMPLICITE, Y COMPRIS LES GARANTIES DE QUALITÉ MARCHANDE ET D'ADAPTATION À UN USAGE PARTICULIER EST LIMITÉ POUR UNE DURÉE DE 1 AN À COMPTER DE LA DATE DE L'ACHAT ORIGINAL DE CE PRODUIT.

CES GARANTIES ET RECOURS DEMEURENT EXCLUSIFS À LA VENTE ET L'UTILISATION DE CE PRODUIT. AUCUNE AUTRE GARANTIE, ORALE OU ÉCRITE, EXPLICITE OU IMPLICITE, NE SERA ÉMISE.

IMPECCA™ NE PEUT PAS ÊTRE TENU RESPONSABLE POUR DES DOMMAGES SPÉCIAUX, ACCIDENTELS, CONSÉQUENTS, DIRECTS OU AUTRES CONNUS OU QUI AURAIENT PU ÊTRE COMMUNIQUÉS À IMPECCA™, Y COMPRIS LA PERTE DE PROFITS, DE BIEN-ÊTRE, DE BIENS ET DE BLESSURES RÉSULTANT D'UNE VIOLATION DE LA GARANTIE, L'INCAPACITÉ D'UTILISER LE PRODUIT OU EN VERTU DE TOUTE THÉORIE JURIDIQUE EN CONTRAT OU DÉLIT. LA RESPONSABILITÉ D'IMPECCA EST LIMITÉE AU PRIX D'ACHAT PAYÉ AU VENDEUR EN DÉTAIL DU PRODUIT DÉFECTUEUX.

Aucun revendeur, agent ou employé d'Impecca™ n'est autorisé à effectuer une modification, une extension, un changement ou un amendement de cette garantie sans le consentement écrit et l'autorisation d'Impecca™.

Certains états ne permettent pas l'exclusion ou la limitation des garanties implicites ou de responsabilité en lien avec des dommages accidentels ou des dommages consécutifs ou ne permettent pas une limitation sur la durée de la garantie implicite. Donc, les limitations ou exclusions ci-dessus peuvent ne pas s'appliquer à vous. Cette garantie vous donne des droits légaux spécifiques et vous détenez d'autres droits, qui peuvent varier d'état en état.

Note : Notre centre de la garantie effectue la livraison uniquement qu'aux États-Unis continentaux.

